

www.valcar.net

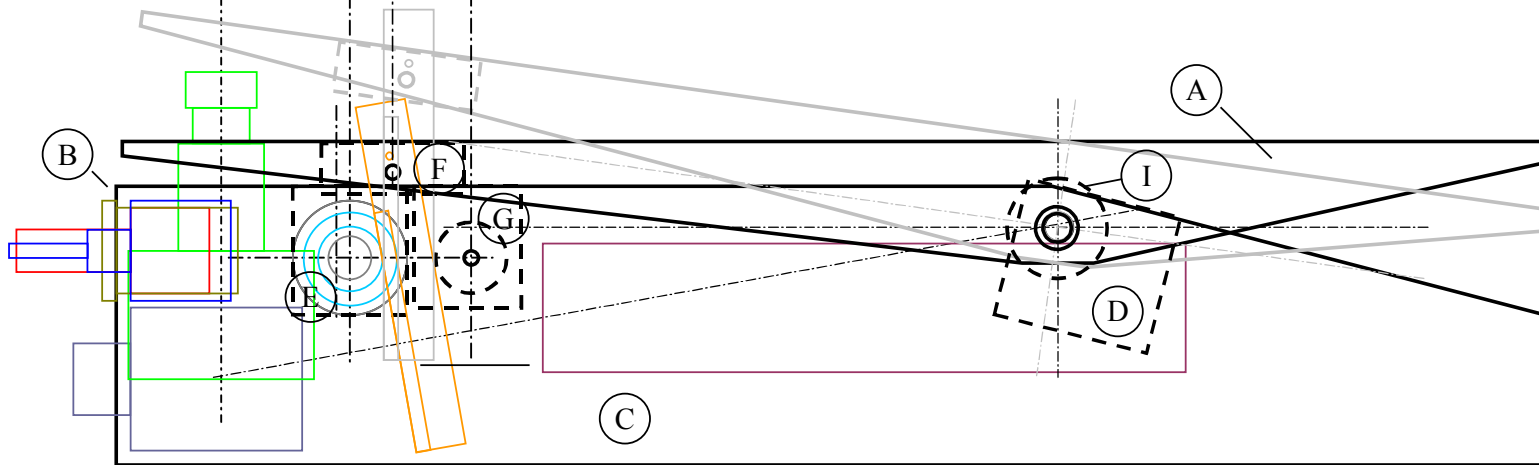

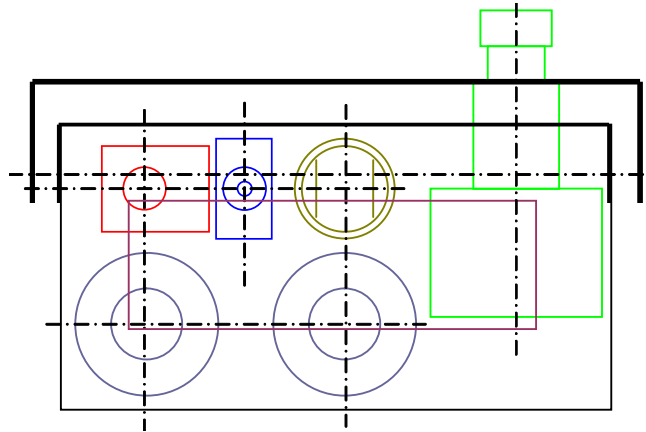

Peça	Função	Quantidade	Material
A	Alavanca do pedal	1	Chapa de alumínio de 1,5 mm
B	Caixa de fixação	1	Chapa de alumínio de 1,5 mm
C	Tampa lateral	1	Chapa de alumínio de 1,5 mm
D	Articulação do pedal	1	Chapa de alumínio de 1,5 mm
E	Suporte dos potenciômetros	1	Chapa de alumínio de 1,5 mm
F	Articulação da cremalheira	2 (medidas espelhadas)	Cantoneira de alumínio de 3 mm
G	Suporte da roldana	2 (medidas espelhadas)	Chapa de alumínio de 1,5 mm
H	Roldana da cremalheira	1	Nylon ou Teflon
I	Mancal da articulação	2	Bronze ou Latão

www.valcar.net

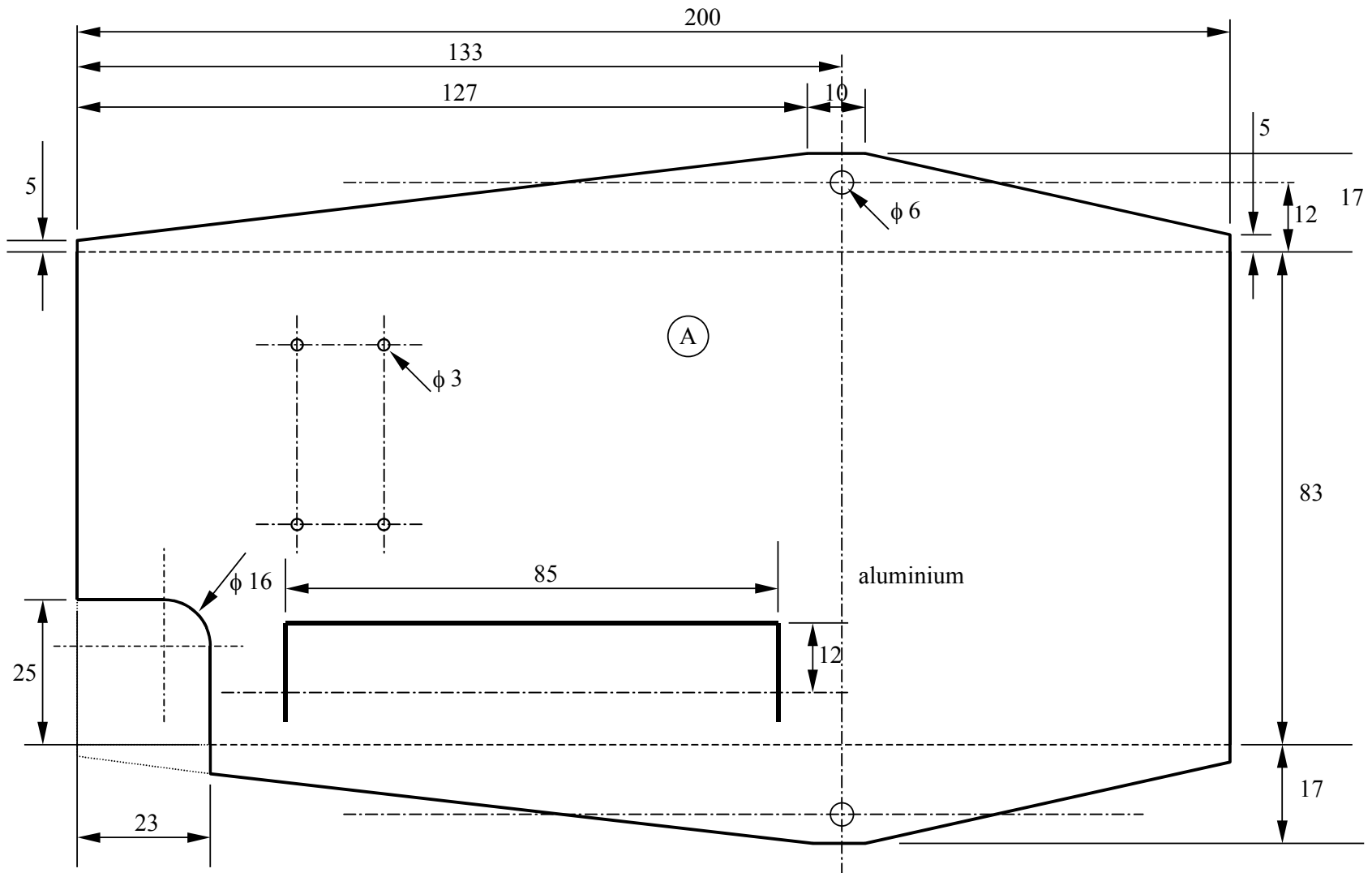

www.valcar.net

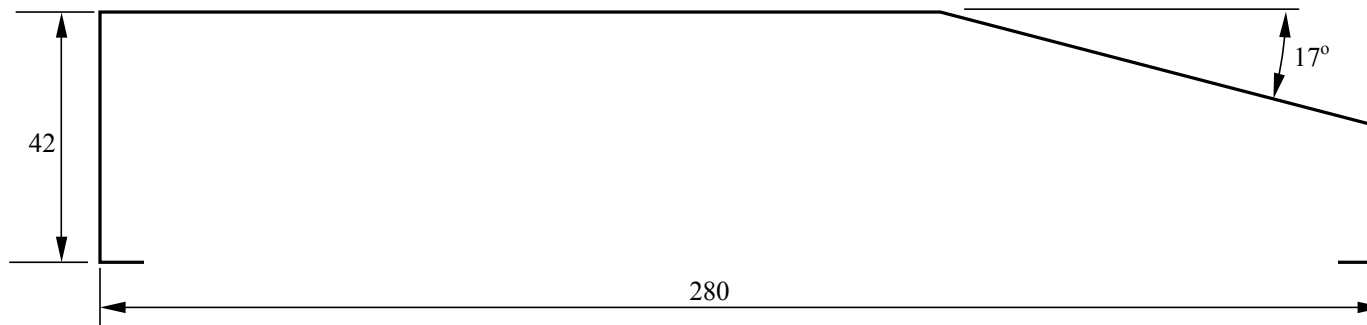
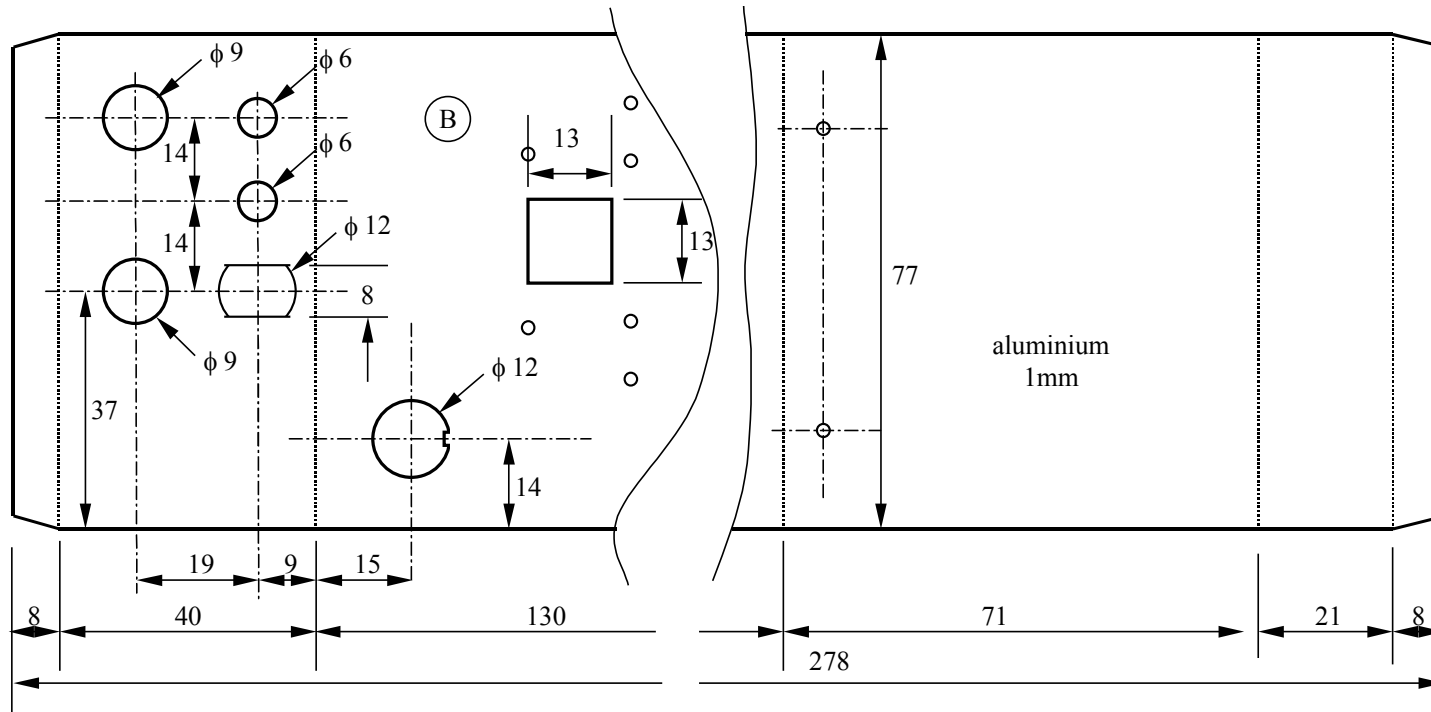

www.valcar.net

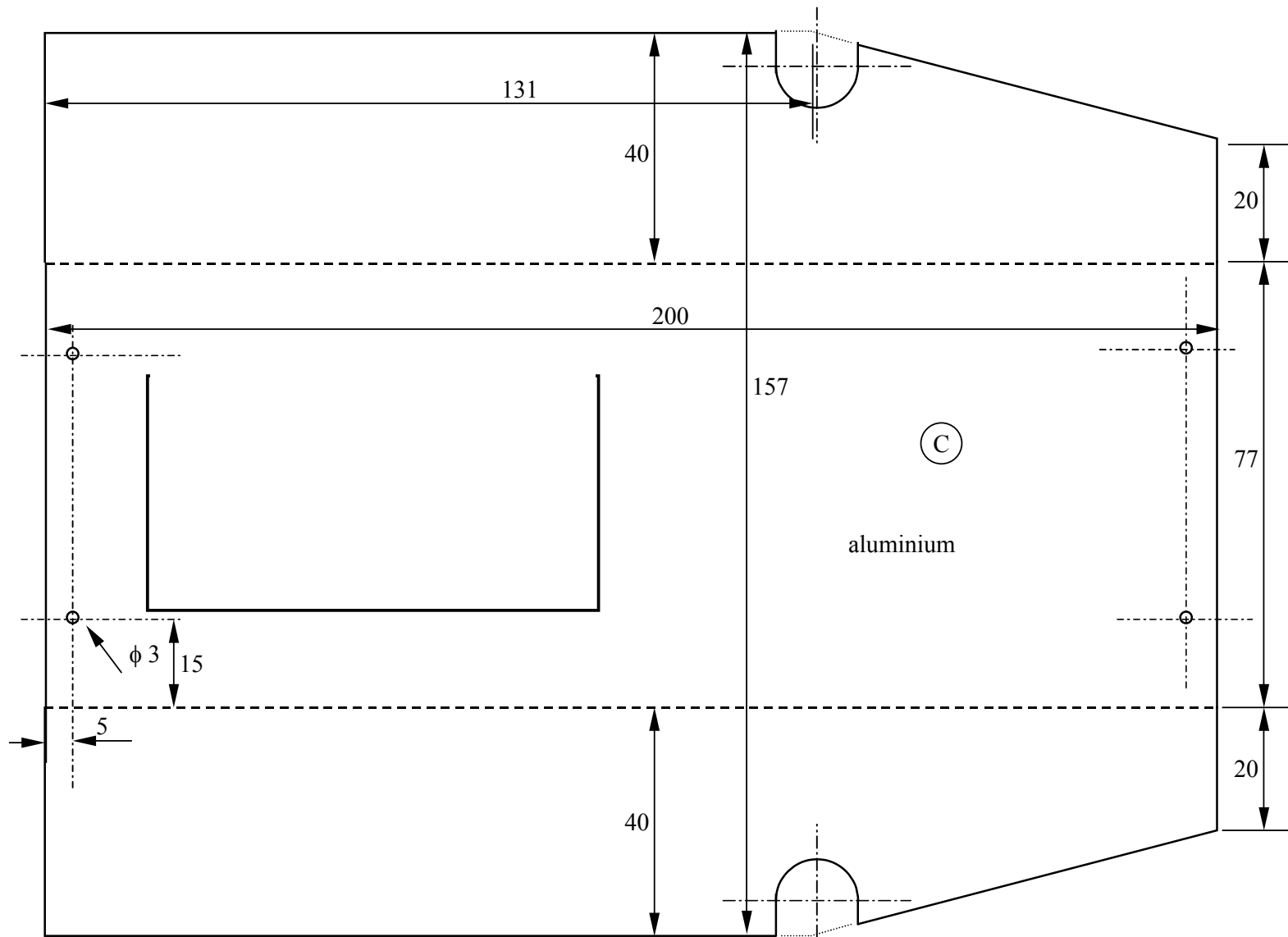

www.valcar.net

